



COMPANY  
WITH QUALITY SYSTEM  
CERTIFIED BY DNV  
ISO 9001

# panorammic



# 35.12 K

## PANORAMIC 35.12 K

MODEL		P 35.12 K
<b>WEIGHT</b>		
Total operating weight (with forks)	kg	8650
<b>PERFORMANCE</b>		
Rated maximum load	kg	3500
Maximum lift height	mm	12370
Maximum forward reach	mm	8120
Lift height at full capacity	mm	12370
Reach at full capacity	mm	3500
Capacity at full lift height	kg	3500
Capacity at full forward reach	kg	1000
Tear-out force with 800 l bucket	kg	4830
Drawbar pull	kg	5850
Carriage rotation	deg	140
<b>SPEED</b>		
1 <sup>st</sup> gear	kph	7/11 <sup>(1)</sup>
2 <sup>nd</sup> gear	kph	25/40 <sup>(1)</sup>

<sup>(1)</sup>With turbocharged engine option

## Integral side-shift

■ Patented by Merlo, integral chassis sideshift permits lateral adjustment of the boom, for precise load placing. Unlike sideshift attachments, the integral Merlo design does not derate load capacity, or increase the effective width of the load.

■ It can be used with any attachment fitted, at any stage in the operating cycle, and does not require the use of boom end hydraulics - leaving them free for attachments!

■ Side-shift with boom extended:  $\pm 330$  mm

## Frame levelling

■ Frame levelling (or 'Sway control') permits the chassis to be transversely levelled with respect to the ground. Lifting is then vertical, for both safety and maximum capacity.

■ On transverse slopes it is essential to be correctly levelled before attempting to lift and, in conjunction with boom side-shift and stabilisers, frame levelling ensures the best handler use in all conditions.

■ Slope correction:  $\pm 9^\circ$ .

## Front stabilisers

■ Hydraulic independent control. In retracted position the best possible visibility is obtained; in working position side shifting and frame levelling can still be operated. Compact design ensures site access.

### SAFETY DEVICES

- An overload warning device activates both audible and visual signals and blocks further overloading actions.
- Automatic lock of frame levelling and stabilisers when boom exceeds a preset safety angle.
- All boom and hydraulic cylinders are fitted with pilot-operated check valves.
- The "Fail-safe" parking brake type automatically locks when the diesel engine is turned off.

### BOOM

- Three telescopic sections, made of high yield steel, each sliding on adjustable anti-friction pads.
- The extension mechanism and hydraulic pipes are housed inside the boom to avoid any site damage.

### CAB

- The high yield steel frame conforms to ROPS (ISO 3471) and FOPS (ISO 3449) standards.
- Opening front and rear windows are fitted with wash/wipe systems. The upper part of the two-section door can be locked in the open position for increased ventilation.
- Air conditioning is available as an option.
- Instrumentation includes: tachometer/revolution counter, hour meter, fuse box, fuel level, coolant temperature, annunciator panel showing blocked engine



### P 35.12 K

A mm	5005
B mm	1440
C mm	2750
D mm	815
E mm	4100
F mm	480
H mm	2220
L mm	2420
M mm	995
P mm	2440
R mm	3920
S mm	4940
Z mm	850

air filter, hydrostatic oil level and temperature, engine oil pressure, coolant temperature, parking brake warning light.

- Boom movements are controlled with "2 in 1" joysticks controls.

### "RING OF STEEL"

• The periphery of the chassis is completed by a solid high yield steel bar, providing a "Ring of Steel" as protection to the engine and fuel reservoir, and assuring good stability.

### STEERING

• All four wheels are steered, with the operator being able to select one of three steering modes. Auto-synchronisation realigns the steering wheels should they become misaligned:

- Front Wheel Steer.
- Four Wheel Steer.
- Crab Steer.

### ENGINE

• The engine is located longitudinally on the right side of the chassis (Merlo patent). It is a low emission 4 cylinder Perkins 1004-42

### DIMENSIONS

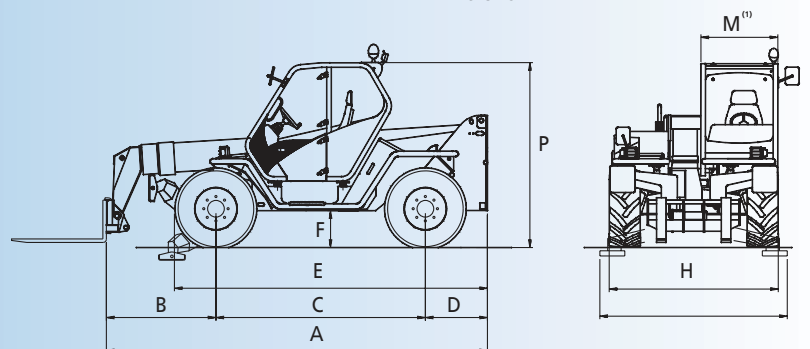

### OUTSTANDING MANOEUVRABILITY

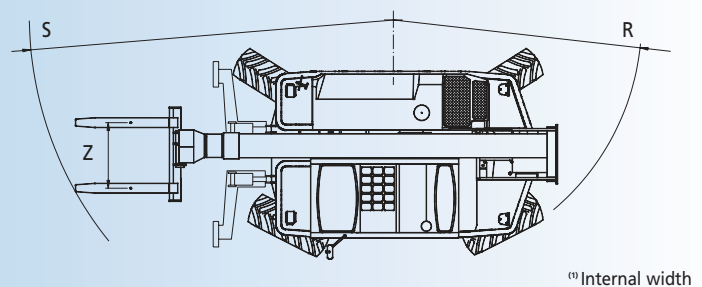

<sup>(1)</sup>Internal width

Diesel engine (97/68/CE), with direct injection and water cooling and 61.5 kW power at 2400 rpm (ISO 3046/1).



• Anti-straw protection on oil and water radiators.

### CARRIAGE

• The 'Tac-Lock' quick attachment fitting system is hydraulically controlled from the cab.

- Two boom-end mounted hydraulic lines are provided, which can be combined as a single double acting service.

### FORKS

Floating type with a length of 1200mm and section 125 x 45mm. Centre to centre fork distances manually adjusted from between 450 up to 1010mm.



# PANORAMIC 35.12 K

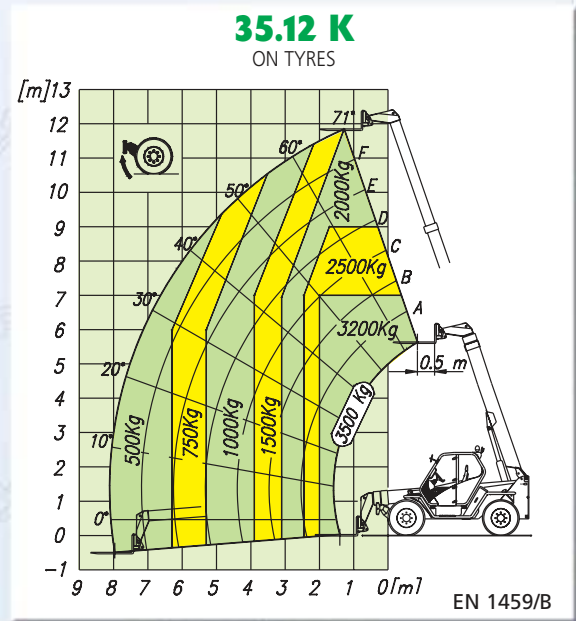
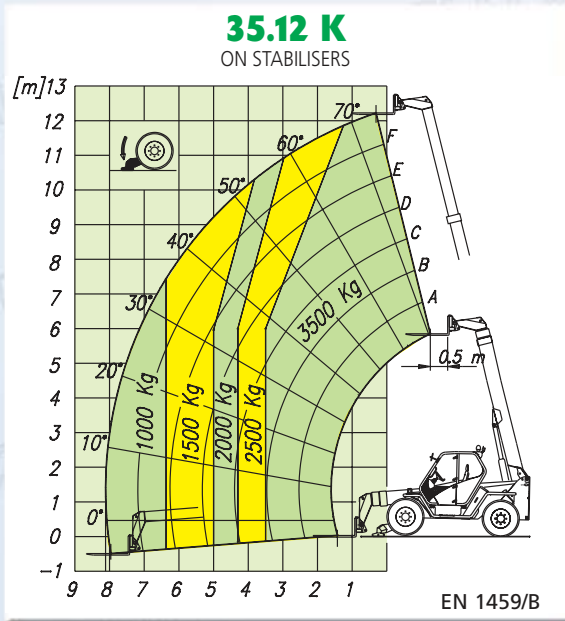

## “LOAD-SENSING”

- The “Load-Sensing” hydraulic system automatically regulates pump delivery to ensure most efficient use of engine power. Pump output is automatically adjusted to suit load conditions, ensuring fast but controllable movement, and reducing power requirements.
- Variable delivery axial pistons pump with “Load-Sensing” control. The operating pressure is 210 bar with a maximum flow of 120 l/min.

## ELECTRICS

- 12V system with 100Ah battery and 65A alternator.
- Full road lighting and flashing beacon.

## CAPACITIES

- Hydraulic oil: 95 l
- Diesel fuel: 155 l
- Hydrostatic oil: 12 l
- Engine oil: 8,5 l
- Coolant: 12 l

## TYRES

- 400/70-24 14PR

## HYDROSTATIC TRANSMISSION

- The hydrostatic transmission ensures automatic and continuous speed regulation from standstill to maximum speed, simply by operating the accelerator pedal.
- The two speed range gear box is electrically operated.
- An “Inching-Control” makes it possible to precisely vary travel speed independently of engine speed.
- With the “Finger-Touch” system it is possible to change driving direction even when the machine is moving, without the operator having to remove his hands from the steering wheel.
- Permanent four-wheel drive traction, with drop portal axles to ensure excellent ground clearance.



## BRAKES

- Hydraulic service disc brakes are fitted to all four wheels, operating on the differential output shafts.

- A ‘Fail-safe’ spring-operated, hydraulic release, disc parking brake is fitted to the main transmission output shaft.

## OPTIONS

- Cab mounted working lights
- Turbo charged engine with speed up to 40 kph
- Rear differential lock
- Prearrangement for attachments requiring two hydraulic services (es. concrete mixer)
- Air conditioning

## Internal width 995mm

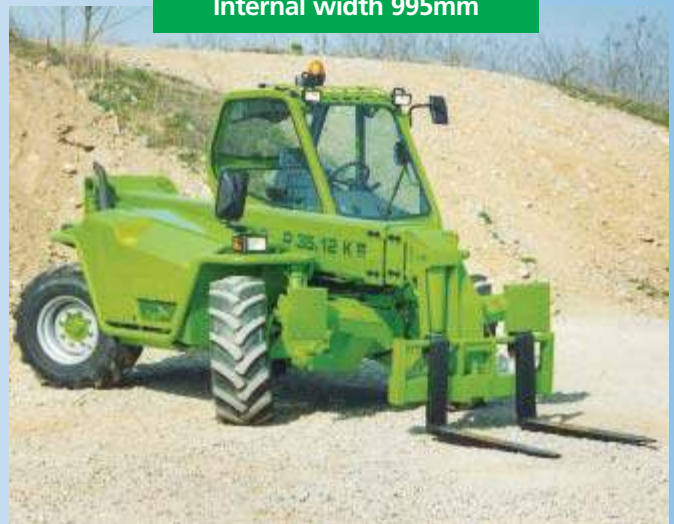

An enormous range of interchangeable attachments and options increase the versatility and performance of the PANORAMIC handlers

Concrete skip



Bucket



Winch



Concrete mixer



Jib with winch



**MERLO**

**MERLO SPA INDUSTRIA METALMECCANICA**

12020 S. Defendente di Cervasca (CN) - Italy

Tel. +39 0171 614111 - Fax +39 0171 614100

[www.merlo.com](http://www.merlo.com) - [info@merlo.com](mailto:info@merlo.com)



**MERLO FRANCE**

[info@merlo-france.fr](mailto:info@merlo-france.fr)



**MERLO UK**

[info@merlo.co.uk](mailto:info@merlo.co.uk)



**MERLO DEUTSCHLAND**

[info@heinrichs-merlo.de](mailto:info@heinrichs-merlo.de)



**MERLO IBERICA**

[servicios\\_generales@merlo-iberica.es](mailto:servicios_generales@merlo-iberica.es)